

# EAGLE STRUCTURAL PANELS

## ACOUSTICAL - INSULATED

Modular panel design permits total flexibility to form enclosures of all shapes and sizes. Units can be floor, ceiling or roof mounted and weatherproofed for exterior installation. Interlocking panels are self-supporting and require a minimum of additional framework.

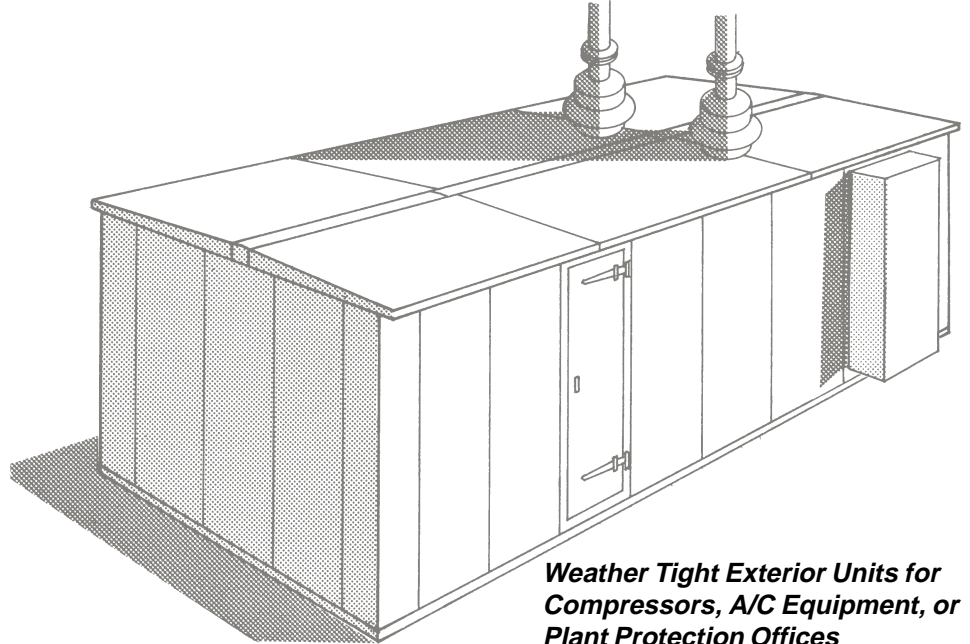

***Weather Tight Exterior Units for Compressors, A/C Equipment, or Plant Protection Offices***

### FEATURES

- Totally prefabricated
- Lift off roof panels for quick accessibility
- Variable panel facing  
Painted Steel  
Stainless Steel  
Aluminized Steel
- Solid panel facing both sides for maximum sound transmission reduction
- Combination solid exterior panel facing with perforated steel interior for noise absorption as well as transmission reduction
- Variable panel thicknesses; 3", 4", 5" & 6" & More

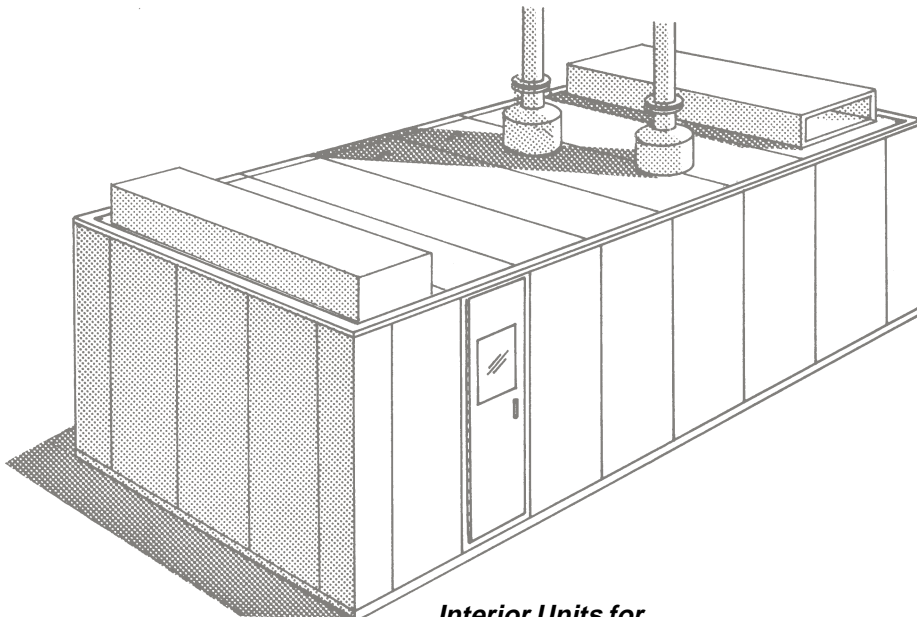

***Interior Units for Compressors Test Chambers Plant Offices***

## APPLICATIONS

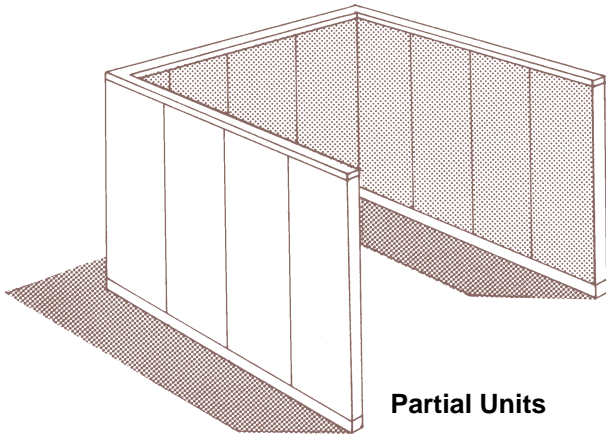

**Partial Units**

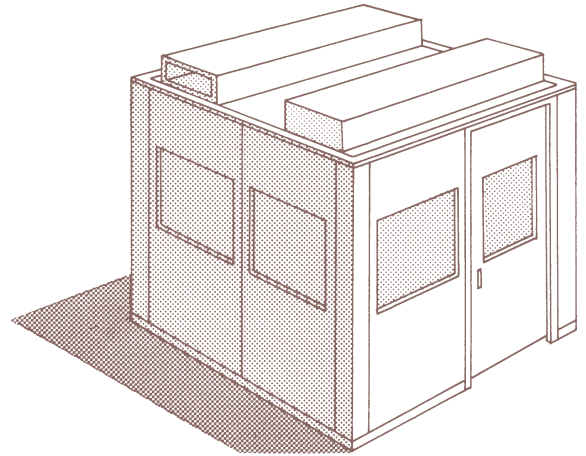

**Plant Offices or Operators Control Booth**

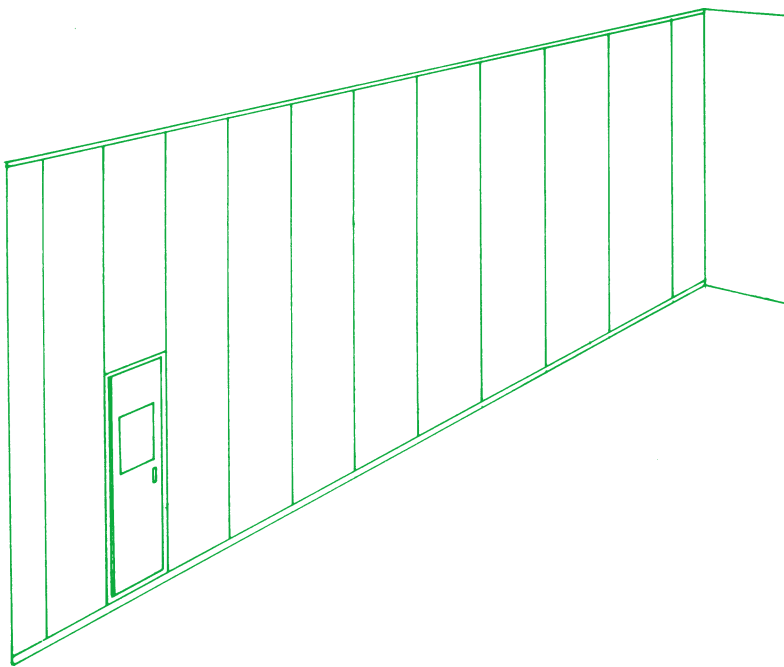

**Full Room Barriers Floor to Roof**

**EAGLE Panels can be erected quickly and with a minimum of effort.  
No special tools or skilled labor is required.  
Detailed information of assembly including material list furnished with each enclosure.**

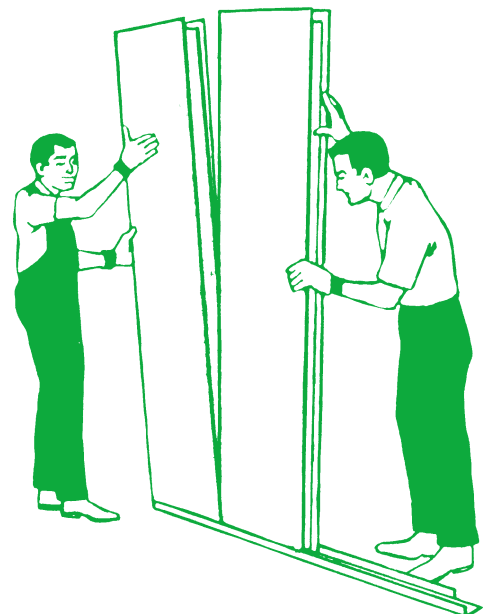

# CONSTRUCTION DETAILS

Sponge Neoprene Gasket  
For Interior Units

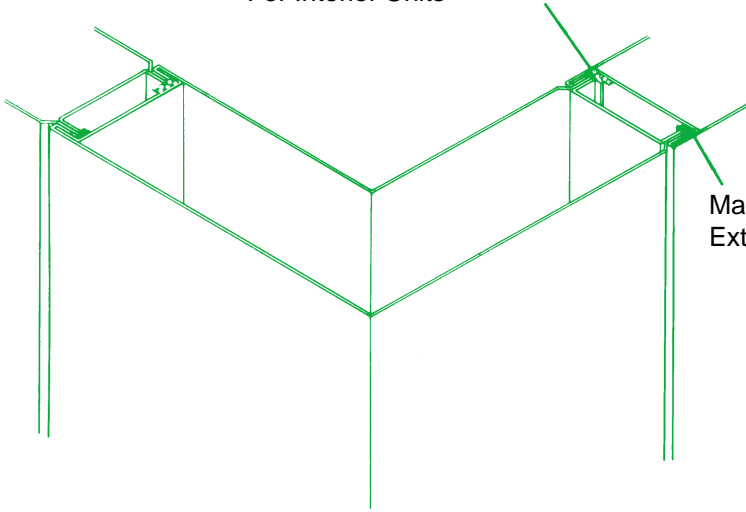

Mastic Seal for  
Exterior Units

Sponge Neoprene Gasket

**Perforated** Inner Panel  
Surface With Solid  
Outer Panel Surface  
To Combine Noise  
Reduction And  
Sound Attenuation.

**Solid** Inner Panel  
Surface With Solid  
Outer Panel Surface  
To Combine Noise  
Reduction And  
Sound Attenuation.

Base Channel

Sponge Neoprene Gasket

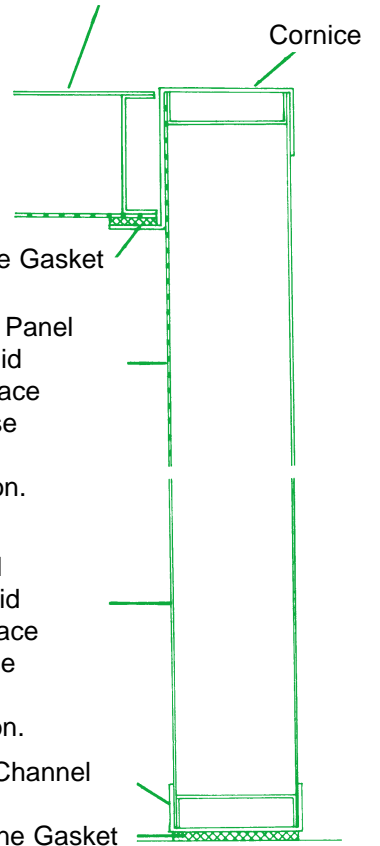

## Horizontal Section Through Panel Connections

Lift Off Roof Panels

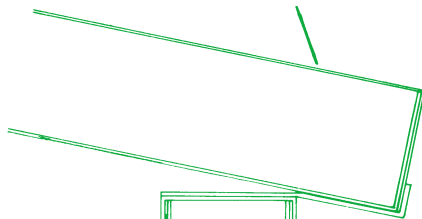

**Perforated** Inner  
Panel  
Surface With Solid  
Outer Panel Surface  
To Combine Noise  
Reduction And  
Lift Off Roof Panel

**Solid** Inner Panel  
Surface With Solid  
Outer Panel Surface  
To Combine Noise  
Reduction And  
Sound Attenuation.

Base Channel

Sponge Neoprene Gasket

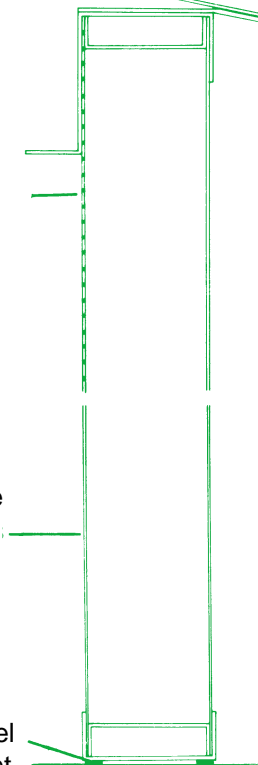

## Section Through Paneling For Interior Units

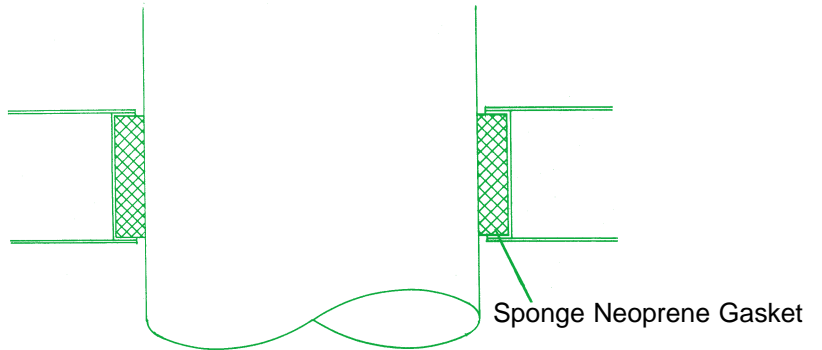

## Section Through Panel Openings For Silencers, Pipes, etc.

## Section Through Paneling For Exterior Units

## ACCESSORIES

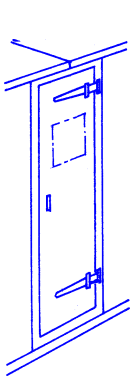

Single door for exterior units complete with strap hinges and safety latches.

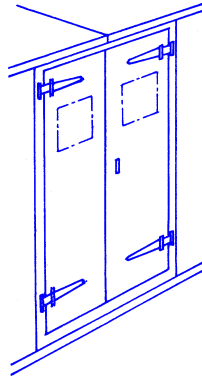

Double door for exterior units complete with strap hinges and safety latches.

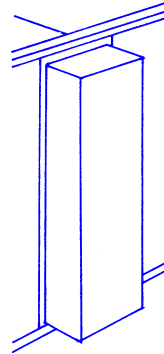

Ventilation panels for air in-take or air exhaust with fan.

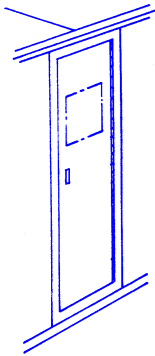

Single door for interior units complete with continuous hinges and three point latches.

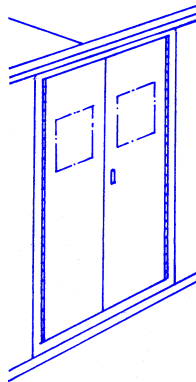

Double door for interior units complete with continuous hinges and three point latches.

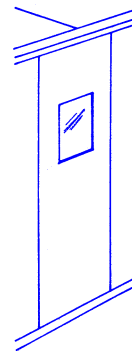

Vision panels with a safty glazing.

# ***Eagle Panels***

AN ADVANCE COMPANY

2500 BROOKPARK RD.

CLEVELAND, OH 44134-1407

1-216-741-1800 1-216-741-7153(FAX)

1-800-988-0632 1-877-868-4890(FAX)

*www.eaglepanels.com*

*e-mail info@eaglepanels.com*